

**JIN<sup>△</sup>ONG**  
晋工新能源

**Green-Machine**  
**Drive the future**  
**Pure Electric Wheel Loader**



**JGM857E**

Fujian JinGong Machinery Co.,Ltd

**Pure Electric Loader**

Charing time: 60 - 90 Min

Endurance time: 7-9 hour(Heavy duty working condition)

/8 - 12 hour (General Working condition)



# Outstanding Characteristics of Pure Electric Loader

## High Performance

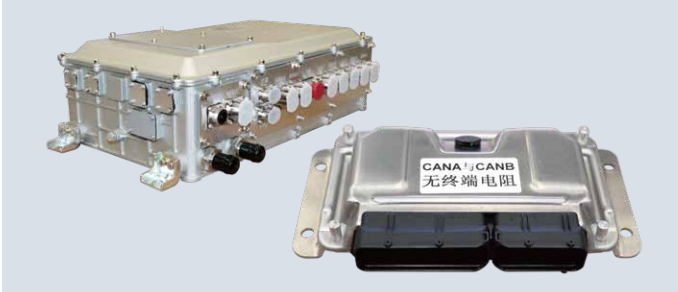

The whole machine adopts the central integrated controller, which has strong computing ability and equipped with the solenoid valve IO drive module and the all-in-one high-voltage distribution module. The driving and shoveling work are calculated and matched by the central controller in real time, thus achieving the effects of accurate control, quick response, high efficiency and energy saving, and achieving the best performance of the whole machine.

## Excellent Battery Life



Equipped with large-capacity lithium iron phosphate battery, it can be fully charged in 1-1.5 hours with double guns. The battery has its own heating and cooling system, which can guarantee the best working temperature of the battery in real time, and good for protect the battery life. (210kWh-350kWh power capacity can be selected according to user requirements, and the endurance can be up to 7-12 hours).

## Brand New Instrument



The 7-inch high-definition digital LCD screen displays the motor response, gear position, temperature, pressure, light and etc in real time. Also display all the vehicle failure information and guide the driver to operate.

## Strong Motivation

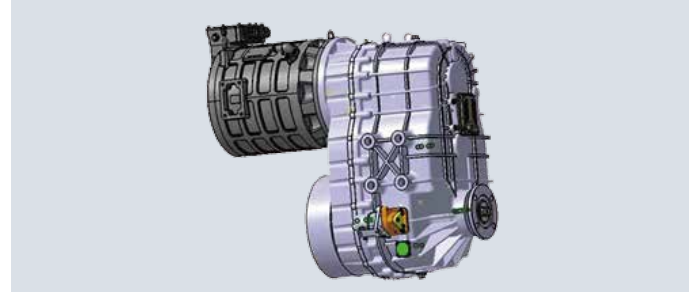

The whole machine adopts double motor drive system, which can realize independent control of work and walking, save more energy and have stronger power. Double motors are made of CRRC permanent magnet synchronous motors of the first-class domestic brands, which are characterized by high torque, high power, abundant vehicle power, lifetime maintenance-free, low noise, small vibration, quick start and more comfort.

## Extremely Reliable



The whole machine and battery are equipped with high-power cooling system, which is independently controlled and has good heat dissipation. It can adjust and maintain the working temperature of battery, motor and hydraulic pressure in real time to ensure the best running state of the system. At the same time, the electronic fan has the function of positive and negative rotation dust removal to prevent dust accumulation.

## Intelligent Control



All operating devices have an electric signal feedback system, which feeds back the driver's operations to the vehicle controller in real time. The controller performs data analysis, matching and intelligent learning according to the feedback signals, and makes the best relevant response actions.

# Outstanding Characteristics of Pure Electric Loader

## Driving Comfort



Standard equipped with air conditioning, circulating air enters from the cab, and cold air blows to people's face from the main air outlet in the front, which meets the requirements of human comfort.

## Sturdy And Wear-resistant



The new bucket with enlarged side plate has a firmer structure, which visually feeling larger bucket shape and more reliability. Higher backplate prevent the material not spill out when the bucket is closed. Adjustable bucket-retracting limit ensures that both sides of bucket and boom are attached when bucket-retracting. Wear-resistant gaskets are added to each pin shaft of the working device to reduce the shaking of the working device.

## Excellent Operation

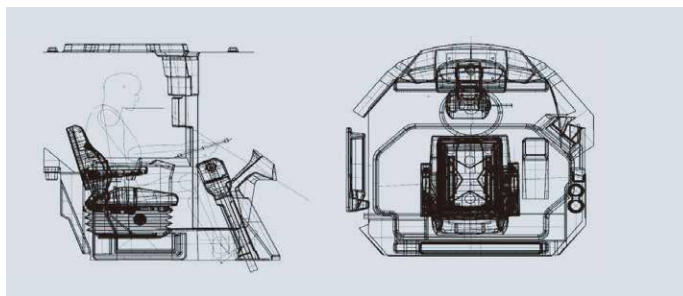

Through the simulation design of ergonomics, mainly considered the common operating components of drivers such as joystick, steering column, switch buttons, etc. to improve the comfort and convenience of operation.

## Heavy-duty Reliable



Using the JinGong upgraded heavy-duty 50E drive axle and with four planetary gears, has high structural strength, large bearing capacity, long service life and high reliability.

## Safety And Environmental Protection



High reliability, high economy and high quality air compressor. The product has compact structure, light weight, stable and reliable operation, low noise and convenient installation. It is a new generation of safe, environment-friendly and energy-saving air compressor.

## Good Stability

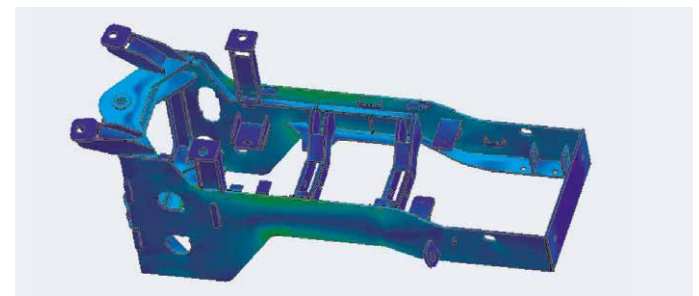

The wheelbase of the whole machine is increased up to 3300mm, and increased the rear suspension distance of the whole machine, so that the load distribution of the front and rear axles of the whole machine is more reasonable and the stability is better. All the structures are analyzed by finite element method, which greatly improves the reliability of the frame.

## Product advantages

Relying on the leading technology of "three electricity" (battery, motor, electric control), according to the characteristics of construction machinery, combined with the design of standardization (standard battery pack), modularization (charging or changing electricity) and platformization (unified voltage platform), the specific construction scene is applied.

### • Working condition analysis of motor

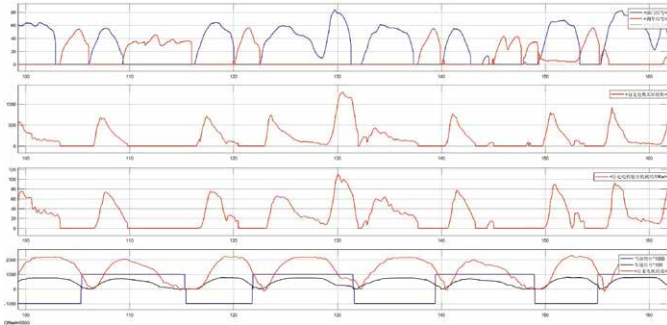

### • Working condition analysis of oil pump motor

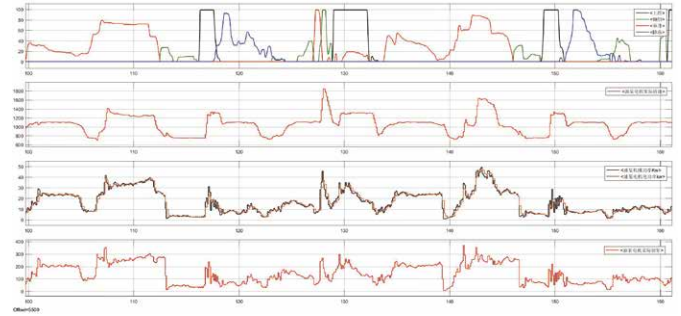

## Comparison of cost and emission

### • Cost comparison of oil and electricity

《Calculation standard: 14 hours a day and 300 days Years》

50 Diesel wheel loader

Oil price: USD 1.17 /liter

Fuel consumption: 15 liters/hour

Daily fuel cost: USD 240

Years fuel cost: USD 71,772

Pure electric 50 wheel loader

Electricity price: USD 0.11 /kWh

Power consumption: 35 degrees/hour

Daily electricity cost: USD 55

Years electricity cost: USD 16,282

**Years saving cost of  
pureelectric 50 loader is about:**

**USD 55,490**

### • Emission comparison of oil and electricity

《Calculation standard: 14 hours a day and 300 days Years》

50 Diesel wheel loader

1 liter of diesel oil = 2.63kg CO<sub>2</sub>

Fuel consumption: 15 liters/hour

Daily CO<sub>2</sub> emission: 552 kg

Years CO<sub>2</sub> emission: 165600 kg

Pure electric 50 wheel loader

Daily CO<sub>2</sub> emission: 0 kg

**Years carbon emission reduction of  
pure electric 50 loader is about:**

**45<sub>Ton</sub>**

(1kg carbon after burned in oxygen, produced about 3.67kg CO<sub>2</sub>)

## Specifications

### Description

Total cycling time	≤10 S
Boom lifting time	≤5.1 S
A Hinge pin height at Max. height	4,350 mm
B Dumping height	3,100 mm
C Dumping reach at max. height	1,220 mm
D Digging depth	45 mm
S1 Max. tilt angle at ground level	45°
S2 Max. tilt angle at carry	48°
S3 Max. tilt angle at max. height	53°
S4 Max. Dumping angle at full height	45°

## Main specifications

Rated Load	5,500 kg
Bucket capacity	2.5-4.5 m <sup>3</sup>
Breakout Force	170 kN
Operating weight	18200 kg
Driveline Motor power	100/160kW
Working Hydraulics Motor power	105/146/kW
Battery capacity	210\282 \350kWh
Indicative runtime	7-12h

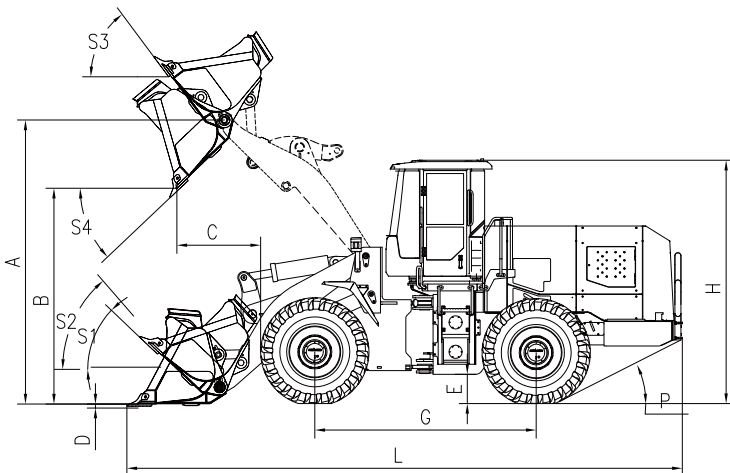

## Dimensions

E Ground Clearance	408 mm
G Wheelbase	3,300 mm
H Cab height	3,500 mm
J Wheel tread	2,290 mm
K Outside width of tire	2,990 mm
L Overall length (with the attachments)	8,200mm
M Steering angle (at any side )	35°
P Departure angle	30°
R1 Min. turning radius with bucket at transporting position	7,140 mm
R2 Turning radius, at outside of tire	6,670 mm

## Transmission system

Traction	>165 kN
Grade ability	30°
Driving speed	8/15/22/38 8/15/22/38

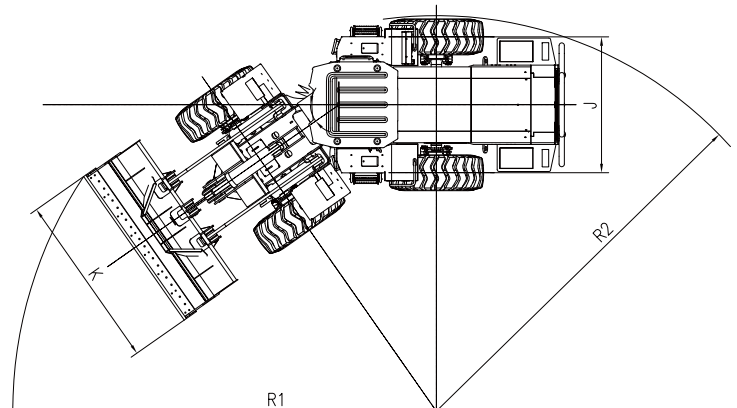



**福建晋工新能源科技有限公司**

Fujian Jingong New Energy Technology Co.,Ltd

ADD : Anhai Qianpu Industrial Zone, Jinjiang City Fujian Province China

Service Phone:400-0922-789

Postcode: 362261

Website: <http://www.jingong-china.com.cn>

E-mail: [overseas@china-jingong.com](mailto:overseas@china-jingong.com)

The product structures and parameters may alter with the technology updating,  
without any notice in advance. If sample differs from the actual product, the latter prevails.



版本号 202201